

RIVETKING® OVAL/ TRUSS HEAD SEMI TUBULAR RIVET DIMENSIONS

SEMI TUBULAR RIVETS

COMMONLY MANUFACTURED & STOCKED IN MATERIALS:
STEEL, ALUMINUM, COPPER, BRASS
 PLATINGS: ZINC, NICKEL, ZNFE, ZNNI, COPPER FLASH, BRASS

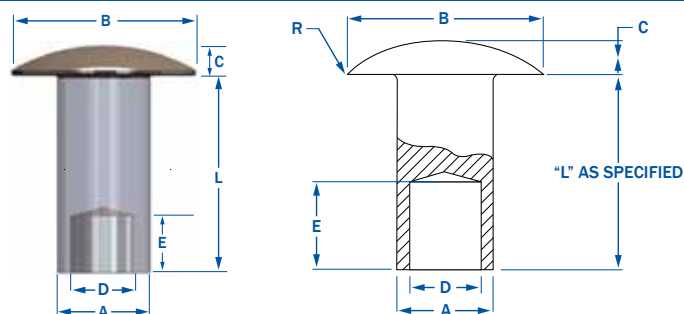

RIVETKING® Semi Tubular Rivets are manufactured in accordance with internal standards and coated with a proprietary wax to insure a smooth rollover and clinch of the assembly.

To calculate the rivet length, add the material thicknesses to be riveted to the maximum clinch allowance "CA". The resulting value is the maximum allowed rivet length. Round off to the nearest 1/32" not exceeding the maximum allowed rivet length.

JOINT STRENGTH TESTING CAN BE PERFORMED IN OUR LAB.
 Contact our applications engineering department for details.

PART CODE	RIVET SIZE	HEAD STYLE	A		B		C		D		E	L	R	CA	MIN. REF. HOLE SIZE
			MAX.	MIN.	MAX.	MIN.	MAX.	MIN.	MAX.	MIN.	DEPTH TO APEX		REF.	REF.	
B-109	1/16"	OVAL	.061	.058	.114	.104	.019	.015	.044	.039	.046	As Specified by User	.16	.032	.067
B-125		TRUSS	.061	.058	.130	.120	.019	.015	.044	.039	.046		.13	.032	.067
F-147	3/32"	OVAL	.089	.085	.152	.142	.026	.020	.068	.062	.064		.22	.045	.093
F-156		TRUSS	.089	.085	.161	.151	.026	.022	.068	.062	.064		.22	.045	.093
G-187		OVAL	.099	.095	.192	.182	.032	.026	.076	.070	.077		.27	.055	.104
J-218	1/8"	OVAL	.123	.118	.223	.213	.038	.030	.090	.084	.094		.31	.062	.128
J-281		TRUSS	.123	.118	.286	.276	.038	.030	.090	.084	.094		.38	.062	.128
M-234	9/64"	OVAL	.146	.141	.239	.229	.045	.035	.107	.100	.126		.27	.093	.152
M-281			.146	.141	.286	.276	.045	.039	.107	.100	.126		.49	.093	.152
M-312		TRUSS	.146	.141	.318	.306	.045	.035	.107	.100	.126		.45	.093	.152
M-375			.146	.141	.381	.369	.065	.060	.107	.100	.126		.53	.093	.152
N-312	5/32"		.157	.152	.318	.306	.068	.058	.110	.103	.126		.31	.093	.165
T-312	3/16"	OVAL	.188	.182	.318	.306	.065	.055	.141	.134	.155		.25	.110	.196
T-375		TRUSS	.188	.182	.381	.369	.065	.055	.141	.134	.155		.53	.110	.196
U-437	7/32"	OVAL	.217	.210	.444	.430	.090	.085	.162	.154	.189		45	.140	.234
Y-437	1/4"		.252	.244	.444	.430	.075	.061	.184	.176	.219		.65	.156	.265
Y-500		OVAL	.252	.244	.507	.493	.085	.071	.184	.176	.219	.72	.156	.265	
V-437		TRUSS	.290	.280	.444	.430	.100	.090	.200	.190	.225	41	.175	.302	
Z-500	5/16"		.310	.302	.507	.493	.090	.085	.213	.206	.243	.59	.187	.328	
Z-562		OVAL	.310	.302	.570	.554	.100	.095	.219	.211	.243	.69	.187	.328	
W-562	3/8"		.377	.368	.570	.554	.100	.095	.286	.276	.312	.69	.218	.390	
W-625			.377	.368	.632	.618	.125	.115	.286	.276	.312	.63	.218	.390	

SEMI TUBULAR LENGTH CALCULATION

To calculate rivet length:

- Add up thicknesses, T1+T2+(T3...) = Work Thickness (WT)
- Select desired rivet diameter and locate the associated Clinch Allowance (CA)
- Add Work Thickness (WT) + Clinch Allowance (CA) = Maximum Rivet Length
- Select rivet below the Maximum Rivet Length to the nearest 1/32".

Example: Fasten 2 pieces of .125" thick steel with steel 3/16" (.375 head) rivets.

- .125 (T1) + .125 (T2) = .250 (WT)
- .110 (CA)
- .250 (WT) + .110 (CA) = .260 (RL) Max.
- .260 (RL) Max, ... Closest standard size .250" (RL)

Rivet Size: 3/16" x 1/4" Rivet King Part# XTT375008SZ

