

# RIVETKING® ZIPSCREW®

THE FOLLOWING PRODUCT IS COVERED UNDER THE FOLLOWING PATENT/TRADEMARK: 3,668,000

ROHS COMPLIANT

The RivetKing® ZipScrew® is a unique fastener which allows for the continuous removal and replacement after it is installed. Most often its used in electronics where the removal and replacement of microchips, chipsets, mosfets, access doors and other areas where the removal of the rivet by the end user may be required. Often times the ZipScrew® is preferred over traditional screws since the user benefits from the installation speed of a rivet and the removability of a screw. Once installed, the user can use a standard hex key to remove the rivet, and later reinstall the rivet just like a screw. The ZipScrew® radial expands resulting in a vibration resistant assembly. Can be used in materials with less than 105 Hv5 hardness.

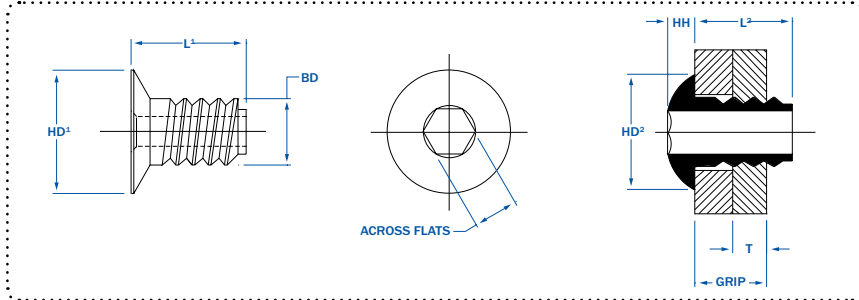

	PART NUMBER	GRIP RANGE	L1 LENGTH AS INSTALLED	L2 LENGTH AS INSTALLED	PCS/POD	HOLE SIZE FRONT SHEET		HOLE SIZE REAR SHEET		BD BODY DIA	HD HEAD DIA AS SUPPLIED	HD2 BODY DIA AS INSTALLED	HH HEAD HEIGHT AS INSTALLED	T THICKNESS REAR SHEET
		MAX	MAX	MAX		+/-	MIN	MAX	MIN					
3.0mm	SDZR - 3006	.112 (2.85)	.202 (5.2)	.157 (4.0)	62									
	SDZR - 3007	.151 (3.85)	.241 (6.1)	.196 (5.0)	52									
	SDZR - 3009	.190 (4.83)	.280 (7.1)	.235 (6.0)	43									
	SDZR - 3010	.229 (5.82)	.319 (8.1)	.274 (7.0)	38	.121 (3.07)	.124 (3.15)	.111 (2.82)	.114 (2.89)	.1107 (2.8)	.230 (5.7)	.240 (6.1)	.055 (1.4)	.064 (1.62)
	SDZR - 3011	.268 (6.81)	.359 (9.1)	.314 (8.0)	34									
	SDZR - 3012	.307 (7.80)	.397 (10.1)	.352 (9.0)	30									
	SDZR - 3016	.422 (10.72)	.515 (13.1)	.467 (11.9)	23									
3.5mm	SDZR - 3506	.112 (2.85)	.202 (5.2)	.157 (4.0)	62									
	SDZR - 3507	.151 (3.85)	.241 (6.1)	.196 (5.0)	52									
	SDZR - 3509	.190 (4.83)	.280 (7.1)	.235 (6.0)	43									
	SDZR - 3510	.229 (5.82)	.319 (8.1)	.274 (7.0)	38	.138 (3.50)	.141 (3.58)	.122 (3.10)	.125 (3.17)	.1215 (3.1)	.235 (5.8)	.240 (6.1)	.055 (1.4)	.064 (1.62)
	SDZR - 3511	.268 (6.81)	.359 (9.1)	.314 (8.0)	34									
	SDZR - 3512	.307 (7.80)	.397 (10.1)	.352 (9.0)	30									
	SDZR - 3517	.463 (11.76)	.553 (14.1)	.508 (12.9)	21									
4.0mm	SDZR - 4006	.112 (2.85)	.202 (5.2)	.157 (4.0)	62									
	SDZR - 4007	.151 (3.85)	.241 (6.1)	.196 (5.0)	52									
	SDZR - 4009	.190 (4.83)	.280 (7.1)	.235 (6.0)	43									
	SDZR - 4010	.229 (5.82)	.319 (8.1)	.274 (7.0)	38	.165 (4.19)		.142 (3.61)	.145 (3.68)	.1415 (3.6)	.235 (6.0)	.250 (6.4)	.055 (1.4)	.064 (1.62)
	SDZR - 4011	.268 (6.81)	.359 (9.1)	.314 (8.0)	34									
	SDZR - 4012	.307 (7.80)	.397 (10.1)	.352 (9.0)	30									
	SDZR - 4015	.385 (9.78)	.475 (12.1)	.430 (11.0)	25									

NOTE: SHEAR AND TENSILE DATA VARIES BASED ON HOLE SIZE, ACTUAL GRIP AND SUBSTRATE MATERIAL SELECTION. FOR REFERENCE DATA PLEASE CONTACT THE ENGINEERING DEPARTMENT. FOR CRITICAL APPLICATIONS, WE SUGGEST OUR ENGINEERING DEPARTMENT PERFORM TESTING ON THE ACTUAL MATERIALS TO BE RIVETED. RESULTING DATA WILL BE PROVIDED UPON REQUEST.

METRIC DIMENSIONS ARE IN PARENTHESIS

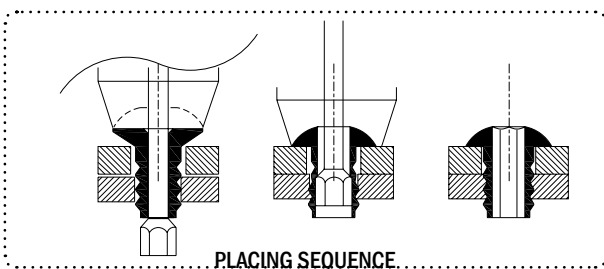

## BUILDING A ZIPSCREW PART NUMBER

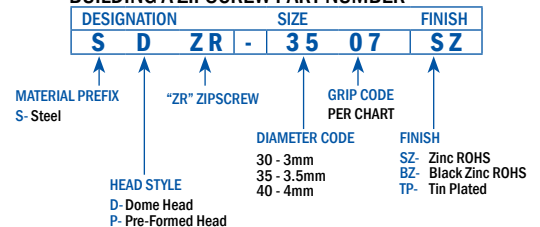

1.800.BUY.RIVET